

Specifications: Model 318F(60) Flanged Valve Horizontal Flow

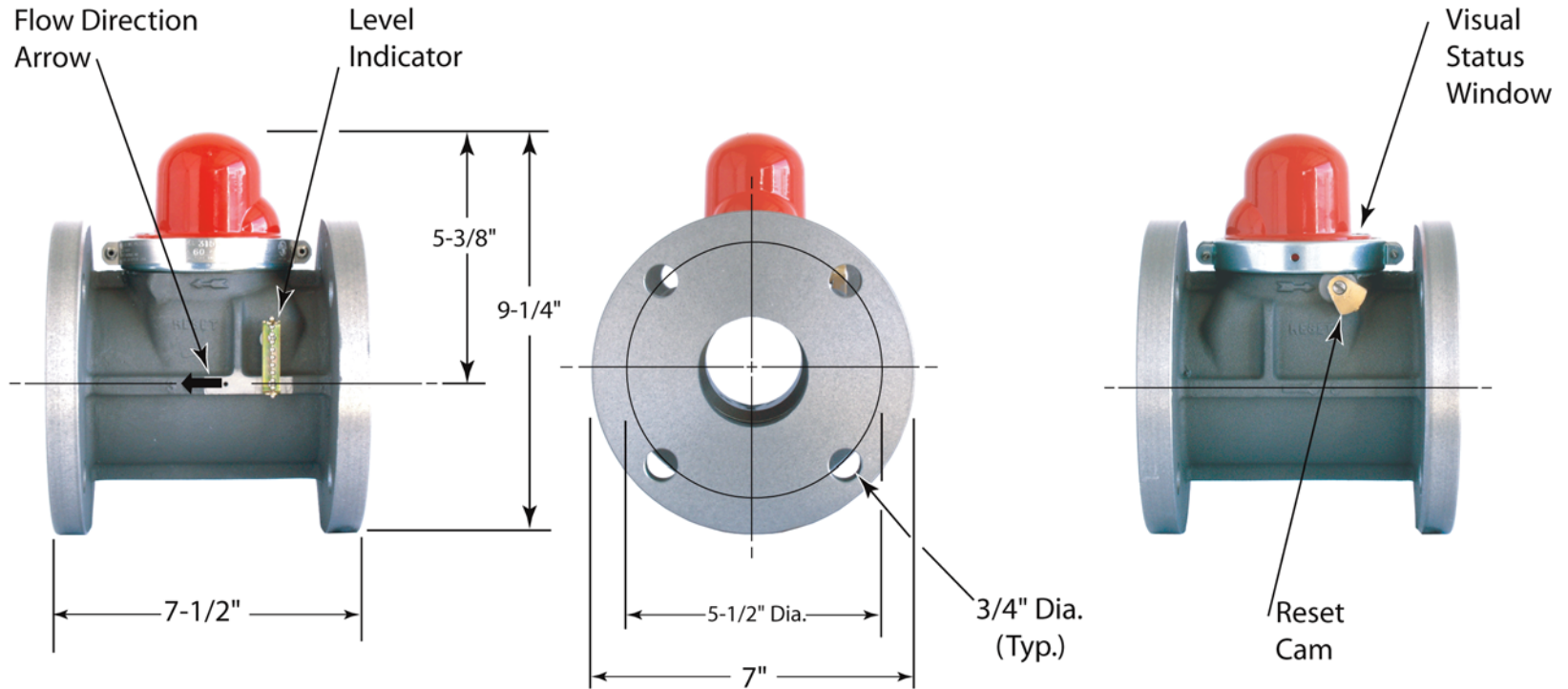

Valve Model#	CA-DSA No.	Length	Height	Diameter	Nominal Pipe Size	APPLICATION	DATA	Diameter On Center	Diameter Hole (Typ.)	Number of Holes
						Max. Pressure	Fuel			
318F	62-01	7-1/2"	5-3/8"	7"	2-1/2"	60 psi	Dry Fuel Gas	5-1/2" Dia.	3/4" Dia.	4

2-1/2" Model 318F California Seismic Valve Flanged Horizontal

FLOW CAPACITY TABLE IWC/PSIG - Capacity S.C.F.H.

Merit Rating: Cv 231 (Equivalent Length of Pipe is 10 Feet)

For determining approximate values at selected natural gas pressures to 60 PSIG

Pressure Drop		8" iwc Inlet	14" iwc Inlet	3 psi Inlet	5 psi Inlet	7 psi Inlet	10 psi Inlet	20 psi Inlet	60 psi Inlet
PSI	IWC								
.0036	0.1	3,997	4,025	4,341	4,580	4,807	5,128	6,078	8,919
.0072	0.2	5,652	5,692	6,138	6,476	6,797	7,252	8,596	12,613
.0108	0.3	6,922	6,971	7,517	7,931	8,324	8,881	10,528	15,449
.0144	0.4	7,991	8,048	8,679	9,157	9,611	10,254	12,156	17,838
.0180	0.5	8,934	8,997	9,703	10,237	10,745	11,464	13,590	19,943
.0216	0.6	9,785	9,855	10,628	11,213	11,769	12,558	14,886	21,846
.0252	0.7	10,568	10,643	11,478	12,110	12,711	13,563	16,078	23,595
.0288	0.8	11,296	11,377	12,270	12,945	13,588	14,498	17,187	25,225
.0324	0.9	11,980	12,066	13,012	13,729	14,411	15,376	18,229	26,754
.0360	1.0	12,627	12,717	13,715	14,471	15,189	16,207	19,214	28,200
.0720	2.0	17,835	17,963	19,376	20,446	21,463	22,903	27,159	39,872
.1080	3.0	21,817	21,974	23,707	25,018	26,265	30,791	33,246	48,821
.1440	4.0	25,162	25,344	27,346	28,862	30,303	32,343	38,368	56,360
.1800	5.0	28,099	28,301	30,543	32,240	33,851	36,134	42,875	62,997

Horizontal Valves



		Sizes Available														Ambient Temperature	
		NPT								Flanged						UL -40° to 150° F CA DSA: -10° to 150°F	
		3/4"	1"	1 1/4"	1 1/2"	2"	2 1/2"	3"	4"	2"	2 1/2"	3"	4"	6"	8"		
Maximum Pressures of Available Sizes	0.5 psi	✓	✓														
	7 psi			✓	✓												
	60 psi	✓	✓	✓	✓	✓	✓	✓	✓	✓	✓	✓	✓	✓	✓	✓	✓
Fluid																	
Natural gas LP gas																	